

Application Development for Hospital-based Home Care Using Anoto Functionality and OSGi

Kristoffer Berggren

2003-04-10

LiU-IMT-EX-343



Linköpings tekniska högskola
Institutionen för medicinsk teknik

Rapportnr: LiU-IMT-EX-343

Datum: 2003-04-10

Svensk titel	Applikationsutveckling för avancerad hemsjukvård med användning av Anoto Functionality och OSGi
Engelsk titel	Application development for advanced home healthcare using Anoto Functionality and OSGi
Författare	Kristoffer Berggren

Uppdragsgivare: IMT, Medicinsk informatik	Rapporttyp: Examensarbete	Rapportspråk: Engelska
---	-------------------------------------	----------------------------------

Sammanfattning (högst 150 ord).
Abstract (150 words)

During the last decades the number of hospital beds has decreased significantly in Sweden, and combined with the growing numbers of elderly citizens amongst the population, the need for larger and better developed home healthcare organisations has increased. People also prefer to be treated at home, or to have a relative being treated at home, if possible. This development results in new problem areas that need to be addressed; status and symptom control is one of them.

This report documents the master's degree project in Medical Informatics at Linköping University in the fall of 2002 and beginning of 2003. One goal of the project was to develop and investigate the ability for patients to perform non-invasive measurements at home using specially designed technology. The other goal was to develop a web-based computer system that allowed patients to send frequent pain assessments to the clinic using modern technology.

Nyckelord (högst 8)
Keyword (8 words)

Home healthcare, Anoto Functionality, OSGi, pain assessment, medical informatics, status control

Bibliotekets anteckningar:

Abstract

During the last decades the number of hospital beds has decreased significantly in Sweden, and combined with the growing numbers of elderly citizens amongst the population, the need for larger and better developed home healthcare organisations has increased. People also prefer to be treated at home, or to have a relative being treated at home, if possible. This development results in new problem areas that need to be addressed; status and symptom control is one of them.

This report documents the master's degree project in Medical Informatics at Linköping University in the fall of 2002 and beginning of 2003. One goal of the project was to develop and investigate the ability for patients to perform non-invasive measurements at home using specially designed technology. The other goal was to develop a web-based computer system that allowed patients to send frequent pain assessments to the clinic using modern technology.

Acknowledgements

I would like to thank all the people involved in this master's degree project, most importantly my supervisors Leili Lind and Dr Daniel Karlsson at the Department of Biomedical Engineering for their support. My fellow collaborate in one half of this project Thobias Ålund deserves a lot of credit for the completion of the SÅLAH system.

I would also like to thank the personnel at LAH for their patience and support during the implementation of the SÅLAH system at their clinic. The help from employees at the Department of Biomedical Engineering have also been most appreciable.

Last of all I wish to thank my family and especially my father Lars Berggren and my sister Rebecca Berggren for calling and waking me up in the mornings.

Table of contents

1.	<u>INTRODUCTION</u>	1
1.1.	<u>PURPOSE</u>	1
1.2.	<u>READING GUIDE</u>	1
1.3.	<u>BACKGROUND</u>	2
1.3.1.	<u>Home Healthcare</u>	2
1.3.2.	<u>Need for Medical Information Systems</u>	2
1.3.3.	<u>Other Home Healthcare Applications</u>	3
2.	<u>OSGI</u>	5
2.1.	<u>SERVICE GATEWAY</u>	6
2.1.1.	<u>Java Environment</u>	6
2.1.2.	<u>Service Framework</u>	6
2.1.3.	<u>Device Access Manager</u>	7
2.1.4.	<u>Log Service</u>	7
2.1.5.	<u>HTTP Service</u>	7
2.1.6.	<u>Client Access Service</u>	7
2.2.	<u>GATESPACE</u>	8
3.	<u>THE STATUS CONTROL SYSTEM</u>	9
3.1.	<u>OBJECTIVES</u>	9
3.1.1.	<u>Emergency</u>	9
3.1.2.	<u>Continuous Monitoring</u>	9
3.2.	<u>MODULES</u>	9
3.2.1.	<u>DCM</u>	10
3.2.2.	<u>MSG</u>	12
3.2.3.	<u>Mobile Phone</u>	13
3.2.4.	<u>Server</u>	13
3.3.	<u>INTERFACE PROGRAM</u>	13
3.4.	<u>COMMUNICATIONS</u>	13
3.4.1.	<u>Signals from the DCM</u>	13
3.4.2.	<u>Signals to the DCM</u>	14
3.4.3.	<u>Communication to the Server</u>	14
3.4.4.	<u>Communication from the Server</u>	15
3.5.	<u>MEASUREMENTS</u>	15
3.5.1.	<u>Blood Pressure Separate Measurement</u>	15
3.5.2.	<u>Blood Pressure Continuous Measurement</u>	16
3.5.3.	<u>Respiratory Frequency</u>	16
3.5.4.	<u>Saturation</u>	17
3.5.5.	<u>Pulse</u>	17
3.5.6.	<u>Weight</u>	18
3.6.	<u>ERROR MANAGEMENT</u>	19
4.	<u>USING OSGI?</u>	21
4.1.	<u>BENEFITS</u>	21
4.1.1.	<u>Secure Messaging</u>	21
4.1.2.	<u>Error Management</u>	21
4.1.3.	<u>Remote Access and User Management</u>	21
4.1.4.	<u>Support</u>	22
4.1.5.	<u>Future Development</u>	22
4.2.	<u>DRAWBACKS</u>	22
4.2.1.	<u>Java compatibility with the iPaq</u>	22
4.2.2.	<u>Understanding OSGi</u>	22
4.2.3.	<u>OSGi on the Server</u>	23
4.2.4.	<u>Support</u>	23
4.3.	<u>OTHER OPTIONS</u>	23
4.4.	<u>CONCLUSION</u>	24

<u>5.</u>	<u>ANOTO TECHNOLOGY</u>	25
5.1.	<u>ANOTO PATTERN AND THE DIGITAL PAPER</u>	25
5.2.	<u>DIGITAL PEN</u>	26
5.3.	<u>SERVICE INFRASTRUCTURE</u>	27
5.4.	<u>SECURITY</u>	28
<u>6.</u>	<u>THE SĀLAH SYSTEM</u>	29
6.1.	<u>OVERVIEW</u>	29
6.2.	<u>METHOD</u>	30
6.3.	<u>THE CLINICAL APPLICATION</u>	31
6.3.1.	<u>Logging into SĀLAH</u>	31
6.3.2.	<u>Active Patients</u>	32
6.3.3.	<u>Inactive Patients</u>	32
6.3.4.	<u>Patient Information</u>	33
6.3.5.	<u>Correct an Erroneous Assessment</u>	33
6.3.6.	<u>The Diagram Page</u>	34
6.3.7.	<u>Search Patient</u>	35
6.3.8.	<u>Equipment Status</u>	36
6.3.9.	<u>Add Patient</u>	36
6.3.10.	<u>Help</u>	36
6.3.11.	<u>Administration</u>	36
<u>7.</u>	<u>DISCUSSION</u>	39
7.1.	<u>IT IN HOME HEALTHCARE</u>	39
7.2.	<u>FUTURE WORK AND ENHANCEMENTS</u>	40
7.2.1.	<u>Status Control System</u>	40
7.2.2.	<u>SĀLAH</u>	40
7.3.	<u>SUMMARY</u>	40
	<u>BIBLIOGRAPHY</u>	43
	<u>APPENDIX A THE ASSESSMENT FORM</u>	45

List of figures and tables

FIGURE 1. OVERVIEW OF THE OSGI SYSTEM [11]	5
FIGURE 2. OVERVIEW OF THE STATUS CONTROL SYSTEM	10
FIGURE 3. OVERVIEW OF THE DCM SYSTEM	12
TABLE 1. BLOOD PRESSURE SEPARATE MEASUREMENT	15
TABLE 2. BLOOD PRESSURE CONTINUOUS MEASUREMENT	16
TABLE 3. RESPIRATORY FREQUENCY MEASUREMENT	17
TABLE 4. MEASURING THE SATURATION	17
TABLE 5. MEASURING THE PULSE	18
TABLE 6. MEASURING THE WEIGHT	18
FIGURE 4. THE ANOTO PATTERN ON A REGULAR PAPER [24]	26
FIGURE 5. THE DIGITAL PEN [24]	26
FIGURE 6. A PEN TRANSACTION [24]	28
FIGURE 7. STRUCTURE OF THE CLINICAL APPLICATION	31
FIGURE 8. THE LOGIN PAGE	32
FIGURE 9. THE PATIENT INFORMATION PAGE	34
FIGURE 10. THE DIAGRAM PAGE	35
FIGURE 11. THE HELP PAGE	37
FIGURE 12: THE ASSESSMENT FORM- THE PAIN DIARY	46

Glossary

API	Application Programming Interface. A set of routines, protocols and tools for building software applications.
ASH	Application Service Handler. Part of the Anoto service infrastructure.
Bluetooth	Bluetooth is a short-ranged radio technology aimed at simplifying communications between devices and the Internet.
BP	Blood Pressure. Can be systolic or diastolic and refers to the pressure the blood inflicts on the arteries.
COPD	Chronic obstructive pulmonary disease (COPD), also called chronic obstructive lung disease, is a term that is used for two closely related diseases of the respiratory system: chronic bronchitis and emphysema. In many patients these diseases occur together, although there may be more symptoms of one than the other. Most patients with these diseases have a long history of heavy cigarette smoking.
DBMS	DataBase Management System. A collection of programs that enables users to create and maintain databases.
DCM	Data Collection Module. The name of the box with measurement devices that is used in the status control system.
ECG	Electrocardiogram. A composite recording of action potentials produced by all the heart muscle fibres during each heartbeat. Used to monitor heart functions and to examine patients for heart diseases.
Ethernet	A local-area network (LAN) architecture developed by Xerox Corporation in cooperation with DEC and Intel in 1976. Ethernet uses a bus or star topology and supports data transfer rates of 10 Mbps. The Ethernet specification served as the basis for the IEEE 802.3 standard, which specifies the physical and lower software layers. It is one of the most widely implemented LAN standards.
FAQ	Frequently Asked Questions. A collection of questions relating to a certain topic, often with answers.

GPRS	General Packet Radio Service. A standard for wireless communications, which transfer data with speeds up to 115 kilobits per second.
High-fi	A high-fi prototype is a usable interface of the system that you are designing. The prototype lacks underlying functionality, but it is used for evaluating and testing the user friendliness of the system.
HTTP	Hypertext Transport Protocol. A protocol used to retrieve web pages from remote servers on the Internet.
HTTPS	HTTP over SSL.
Hyperlink	A link is a reference on a web page that references some other place on the same page or somewhere else on the Internet. If the link is "clickable" that means it is a hyperlink.
IMT	Department of Medical Engineering at Linköping University.
iPaq	The name of the PDA used in the status control project. Manufactured by Compaq and HP.
JAR	Java Archive Files and Resources. A collection of Java classes and other resources in a compressed form.
LAH	Lasarettansluten hemsjukvård – Hospital based home healthcare. The name of the clinic involved in the project.
Low-fi	A low-fi prototype is a paper-based interface of the system you are designing. The low-fi prototype is used for evaluating the user friendliness and is normally implemented as a high-fi prototype for further evaluation.
MSG	Medical Service Gateway. The software part of the status control system that monitors and collects data from the DCM as well as sends and receives data from the server.
OSGi	Open Services Gateway initiative. A foundation with the goal to create a standard for service gateways.
PDA	Personal Digital Assistant. Refers to handheld computerized devices such as mobile computers or

advanced mobile phones.

PIC	A PIC is a microprocessor, a single-chip computer. Single-chip computer means that the entire computer system lies within the confines of the integrated circuit chip.
PLS	Paper Lookup Service. A service which tells the digital pen which ASH to contact for a specified pattern page. PLS is a part of the Anoto service infrastructure.
RS232	RS232 was developed in the 1960s, and among other things, specified an electrical standard, a protocol standard, handshaking, and connector pin-out for serial communication.
RSA	RSA is a public-key cryptosystem for both encryption and authentication; it was invented in 1977 by Ron Rivest, Adi Shamir, and Leonard Adleman, hence the name RSA. The RSA algorithm is based on the fact that there is no efficient way to factor very large numbers. Deducing an RSA key, therefore, requires an extraordinary amount of computer processing power and time.
SGADK	Service Gateway Application Development Kit. A toolset for programming, configuring, and running service gateways.
SQL	Structured Query Language. A question and modelling programming language. Used in databases.
SSL	Secure Sockets Layer. A protocol developed by Netscape for transmitting data secure over the internet.
SSN	Social Security Number. A unique identification number for a person with Swedish citizenship. It is based on the date of birth followed by four digits.
SÅLAH	Smärta-Åtgärd-LAH. Swedish abbreviation for pain action at the hospital clinic for home healthcare.
TINI	Tiny Internet Network Interface. A smart-card with a cpu that can perform data conversion and other tasks.
USB	Universal Serial Bus. A connection port often used at computers or other technical appliances such as digital cameras. Used for communicating between devices.

VAS	Visual Analogue Scale. An instrument definition that tries to measure a characteristic or an attitude.
WAP	Short for the Wireless Application Protocol, a secure specification that allows users to access information instantly via handheld wireless devices such as mobile phones, pagers, two-way radios, smart-phones and communicators.

1. Introduction

This report is based on the Master's Degree Project in Medical Informatics, at the Department of Biomedical Engineering (IMT), Linköping University, Sweden.

The project is a part of the research project "Advanced Home Healthcare Environment" [1], and is divided into two parts. The first part covers developing a system for patients to perform non-invasive measurements in their home, a status control system. The results of the measurements are then sent to a server at the hospital where the patients are enrolled. The thesis covers the development of a requirement specification for the system, as well as an inquiry to decide whether a third party framework called OSGi shall be used in the system.

The second part is based on a previous thesis by Li Hallgren [2]. This part is also described in the thesis by Thobias Ålund [3]. The main goal was to develop a web-based computer system to enable palliative care patients to perform pain assessments in their home on a regular basis using Anoto technology. The caregivers can take part of the result within seconds after the patient has performed the assessment.

1.1. Purpose

The first purpose of this work is to develop a requirement specification for a status control system that will allow patients to perform non-invasive measurements of objective parameters in their home. To analyse whether a third-party software framework called OSGi should be used in the development and implementation of this system was also important.

The second purpose is to develop a computer system, which will make it possible for patients subject to home healthcare, to perform pain assessments in their home. The assessments will be monitored by caregivers at the LAH clinic in Linköping and will be part of the patient's medical records.

1.2. Reading Guide

The intended target audience for this thesis is people with technical background and some basic knowledge of information technology as well as medical care. Most of the material should, however, be understandable by anyone.

The following list is a short description of the chapters and their content:

Chapter 2 gives an understanding of OSGi.

Chapter 3 describes the status control system.

- Chapter 4** discusses the use of OSGi within the status control system.
- Chapter 5** gives an in-depth understanding of the Anoto Functionality.
- Chapter 6** describes the SÅLAH system and the underlying technology.
- Chapter 7** discusses the future for information technology within home healthcare as well as suggests future enhancements for both the SÅLAH system and the status control system.

1.3. Background

1.3.1. Home Healthcare

During the last decades the number of hospital beds has decreased significantly in Sweden [4]. Combined with the growing numbers of elderly citizens among the population, the need for larger and better developed home healthcare organisations has increased. According to surveys, [5], this goes hand in hand with the will of the population. People prefer to be treated at home, or to have a relative being treated at home, if it is possible. The high standard in housing and hygiene has also made the need for the hospital buildings less important [5]. It is, however, not determined whether home healthcare is a cheaper option compared to regular hospital-based care, but it provides other benefits, such as an increased security and comfort for the patients [5].

1.3.2. Need for Medical Information Systems

One of the problems in home healthcare is that patients cannot be monitored, by means of subjective and objective parameters, as thoroughly as hospital-based patients. Due to the geographic distances, caregivers do not have the ability or the resources to visit all patients several times a day. This problem area seems to be well suited to introduce medical information systems, to support the caregivers and provide medical data for them. The research group has been working in cooperation with LAH, a hospital-based home care division of the University-hospital in Linköping. The collaboration will emerge in a study that covers the effects of information technology within home based healthcare [6], [4].

The research group has together with the home healthcare organisations in Linköping identified parameters that would be suited for monitoring. Patient groups that could benefit most from implementing a monitoring system have also been identified. The identified parameters are blood pressure, pulse, saturation, weight and breathing frequency, which all are objective status parameters. The target patient groups are COPD (Chronic Obstructive Pulmonary Disease) patients, patients with heart failure who are being treated at LAH. Furthermore, patients were chosen that are suitable for trying a symptom monitoring system when assessing their pain from home. These patients are all in a palliative state of care and suffer from severe cancer.

An article that described the need for home telecare was published in 1998 [7]. The article was written by scientists at the University of Genova, Italy, and pointed out the most important aspects of home telecare; active measurements and passive monitoring. The key benefits from using a home telecare system according to the authors were cost savings, improved quality of measurements, improving the quality of life, and obtaining new kinds of follow-up procedures. They also pointed out that an introduction of a home telecare system always requires changes in the organisation as well as the education of the medical staff. The largest difficulties that could prevent the adoption of home telecare in a larger scale are the general crisis of the national health-care systems, technical difficulties, and the need for introducing and testing new, and to the physicians unknown, treatment plans.

1.3.3. Other Home Healthcare Applications

In the early 1990's a large project started in Madrid, Spain, where a research group developed a home telecare management system [8]. The purpose of the system was to allow a service centre to perform remote monitoring of biological signals, as well as to manage emergencies that could arise in the patients' homes. The system was tested in Belfast, Northern Ireland in 1994, and was later installed in Torre del Mar, Spain. The design of the system was rather sophisticated considering the level of information technology at that time. In every patient's home two computers were installed with measuring devices to measure blood pressure and ECG. After the patient had performed a measurement the computers used a modem connected to the public phone line to send the data to a server at the service centre. Emergency detectors and alarm triggers were also installed in the patients' homes to ensure that the patients could alarm the service centre in case of an emergency.

At the service centre operators used a computer program to monitor the patient and collect measurement data as well as any alarms. The operators had reserved phone lines that went directly to different emergency services, such as ambulance, police, and doctors. The result of the first study indicated that caregivers received a much better control of the patient, the operators were also able to make fast and efficient decisions that improved the care of the patient.

In 1995 a similar study was made in Northern California, the U.S. [9]. A research group designed a home monitoring system for patients with heart failure. The patients received a scale and a blood pressure cuff that they should use, and report the measurement data into a computerized voice telephone answering system. A computer algorithm evaluated the patient's medical data and compared them to trigger levels set by physicians. If any values were outside the accepted range or abnormal in any other way, a nurse was paged who contacted the patient. The results of the study showed that patients using the system required less resources and hospital-based care than patients not included in the program.

A number of scientists in Greece and USA have started a project to develop and possibly implement a home telecare system that would use wireless technology [10]. The project is very extensive and aims to create a new large market involving every single home in Europe and North America. The objectives include developing a new generation of telemedicine services, new decision support systems, as well as increasing citizen involvement in healthcare. The scientists concentrate mostly on WAP technology to make the client side of the system as small and portable as possible. The performed pilot study involved diabetes

patients that would submit values of some basic measurements they had performed at home using a mobile phone and a PDA. The values the patients submitted would be checked according to a medical knowledge prototype, which is a decision support system based on Fuzzy Logic and Neural Networks. The values were also stored in a database located at the corresponding clinic.

The main difference between these projects and the one being developed by the research group at IMT is that the communication between the equipment for measurements and the clinic is completely computerized. The patients do not need to write down their own measurement values of the objective status parameters, they only need to state their own subjective symptoms, in this case pain. The medical instruments used in this project are also much smaller and more portable than the ones mentioned above.

2. OSGi

This chapter provides an overview of OSGi.

OSGi is an abbreviation for Open Services Gateway initiative, and was founded in 1999 by 15 different companies, including Ericsson, IBM, and Sun. The goal was to create an open standard for services in Service Gateways. A service gateway is a system framework where services from third party producers are communicating with each other, the framework itself, and other external devices. The gateway acts as a platform for many different internet-connected services, for instance games, telephone, multimedia, and Internet. For instance Ericsson's E-box is a service gateway product based on OSGi.

The service gateway provides certain services and allows extended services to be implemented as bundles. A bundle is basically a Java-package with classes and a manifest that states what class to use when starting the bundle. The gateway allows you to dynamically download, install, and start a new service or bundle. All bundles communicate with each other by publishing and collecting services from the gateway's service register. For instance, one bundle can manage the refrigerator in your home service gateway, and can communicate with the bundle controlling your personal dinner manager. The bundles can communicate with each other and make sure all the necessary ingredients for tonight's dinner are available.

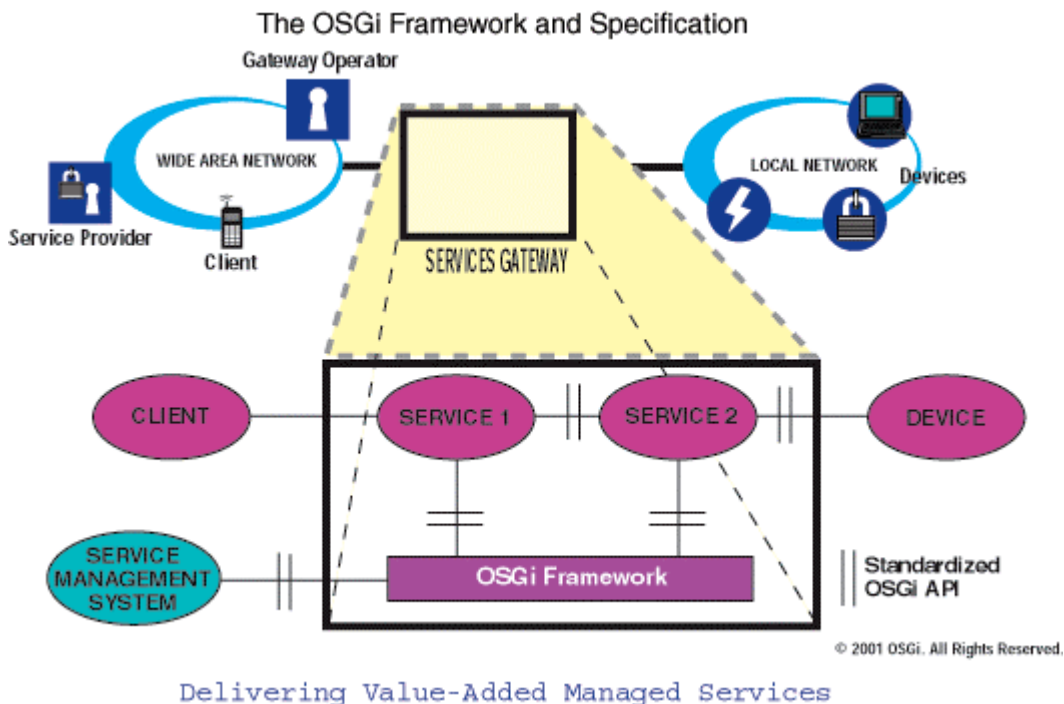

Figure 1. Overview of the OSGi system [11]

The OSGi organisation describes multiple user areas for the service gateway, and among these is Remote Home Healthcare Services mentioned as a prime area for development, [12]:

Remote Home Healthcare Services

The home care segment represents a large and relatively untapped market for service providers. The user benefits come from providing “peace of mind” to relatives of elderly and disabled people through security and monitoring services, and offering communication services such as user friendly home shopping and video telephony. The likely services for this segment are monitoring and sensing devices (such as, motion detectors), personal alarms, assistance tools (simplified Internet home shopping) and communication (for example, e-mail and video conferencing). Again, these services may be bundled with other services to serve vertical-style user markets from a set of horizontal services.”

Unfortunately the current situation is not as easy as OSGi proposes. The medical institutions in Sweden have very strict security requirements regarding medical services and information technology [13]. For instance, they cannot allow medical services being run in a gateway that provides other non-medical services. OSGi is, in its current release, unable to guarantee that a service running in a service gateway does not affect other services in the same gateway. Even if a service do not crash the gateway, it can in some cases use all the data power of the gateway, hence making it unable for the medical services to run properly [13].

2.1. Service Gateway

The core of the OSGi system is the service gateway that provides the framework for the system. It is currently based on the Java programming language. The service gateway consists of the following elements; Java Environment, Service Framework, Device Access manager, Log Service, HTTP Service and Client access service.

2.1.1. Java Environment

In the current release of the OSGi specifications (release 1) all APIs must support the Java 2 package and class definitions. The exact details of required classes and packages are however not specified, but left for the gateway provider.

2.1.2. Service Framework

The service framework provides an environment for developers to write programs that are to be executed on the gateway. The techniques for writing code in the service framework consist of making a bundle. A bundle is basically a Java archive file (JAR) with the following components:

- ÷ Resources to implement zero or more devices. A device is any type of component that communicates with the gateway, for instance a thermometer or a motion sensor. The resources can be Java class files or any other data.
- ÷ A manifest with information that states the static dependencies on other resources, for instance different Java packages, as well as information that declares which class should be used to start and stop the service.

- ÷ Other classes that the framework may need to install, configure, update or activate the service.

With this information the framework can download, activate and control a bundle uniformly.

2.1.3. Device Access Manager

The device access manager provides services for devices and network hardware that may be connected to the gateway. Its main purpose is to make the communication between remote service providers and local devices as easy as possible. The manager is both device and network independent; all it needs is a proper designed driver for the device and/or network. The device access manager uses a network bundle and a device bundle that contains the drivers as well as other information needed to communicate. The key benefits of this are that it is only needed to implement one network bundle that can be used to communicate with any other devices attached to the system.

2.1.4. Log Service

The log service allows Java-based services to write and read entries to and from the log. The log service is easy to implement and is a necessary tool when developing. The log service can be constructed in a variety of ways, sending data to a remote management or spooling it to a local log file.

2.1.5. HTTP Service

The HTTP service included in the OSGi specification runs as a part of the services gateway device. It provides abilities to publish static as well as dynamic content generated from Java Servlets.

- ÷ Support for Java Servlet 2.1 (or higher).
- ÷ Java Servlet Engine.
- ÷ Support for HTTP 1.0 and HTTP 1.1 protocol.
- ÷ Services can register and unregister content into the URI namespace of the HTTP server.
- ÷ Security features such as SSL encryption and HTTP authentication.

2.1.6. Client Access Service

A gateway-resident mechanism providing user access service has been implemented in order to simplify for the developers. The client access service provides automated support for different users to access, use, alter, and modify services, bundles, and data in the gateway.

2.2. Gamespace

Gamespace is one of the companies involved in developing the OSGi specifications. They have developed an implementation of OSGi and have also added some extra features, such as user management. The current release is named Gamespace SGADK 3.2. For further information about Gamespace SGADK the reader is referred to Gamespace SGADK documentation [14].

3. The Status Control System

This chapter covers the development of a status control system that is taking place at IMT. The reader can find further information about the system in the requirement specification, [16].

3.1. Objectives

The main objectives of this project are to satisfy two scenarios described by the caregivers at LAH, an emergency scenario and a continuous monitoring scenario. In both scenarios the patient is being treated at home and has a status control system installed. The patients are suffering from either COPD or heart failure.

3.1.1. Emergency

A patient contacts the caregivers at LAH to report that he/she is feeling ill and suffers from symptoms caused by his/her disease. The caregivers ask the patient to initiate a measurement instantly. The patient performs the measurement and the caregivers receive automatic updates of the patient's measurement values, which can aid the caregiver to decide how soon the patient needs help. In this case "help" can mean a home visit by a doctor/nurse, or calling for an ambulance. It can also mean a telephone contact, by which the caregiver can calm the patient because his/her measured values were fine.

3.1.2. Continuous Monitoring

Relative stable patients perform measurements themselves at home according to agreed intervals. Measurement data is sent to LAH and can be monitored by caregivers. By performing continuous measurements caregivers can be alerted of the patient's health status and can take precautions before the patient becomes seriously ill. Caregivers can also enter limit values for the patient's vital signs so that the system automatically can alert caregivers if a patient falls beyond these values. For instance, a patient with heart failure suffers an increased risk of severe heart implications if he/she gains weight over a short period of time, [15]

3.2. Modules

The status control system is structured in four modules.

- ÷ DCM – Data Collection Module
- ÷ MSG – Medical Service Gateway

- ÷ Mobile phone
- ÷ Server with a database and an interface program for users.

The system shall monitor, control, and gather data from the DCM that performs medical measurements on the patients. Gathered data shall be filtered and verified before the system sends it to a server at LAH. Patients can use the DCM to measure their blood pressure, saturation, breathing frequency, weight, and pulse. The system controlling the box uses a SonyEricsson T39 cell phone to exchange data with a server that is located at LAH. The communication between the MSG and the DCM is Ethernet, the MSG to cell phone connection is Bluetooth, and the cell phone communicates with the server using GPRS.

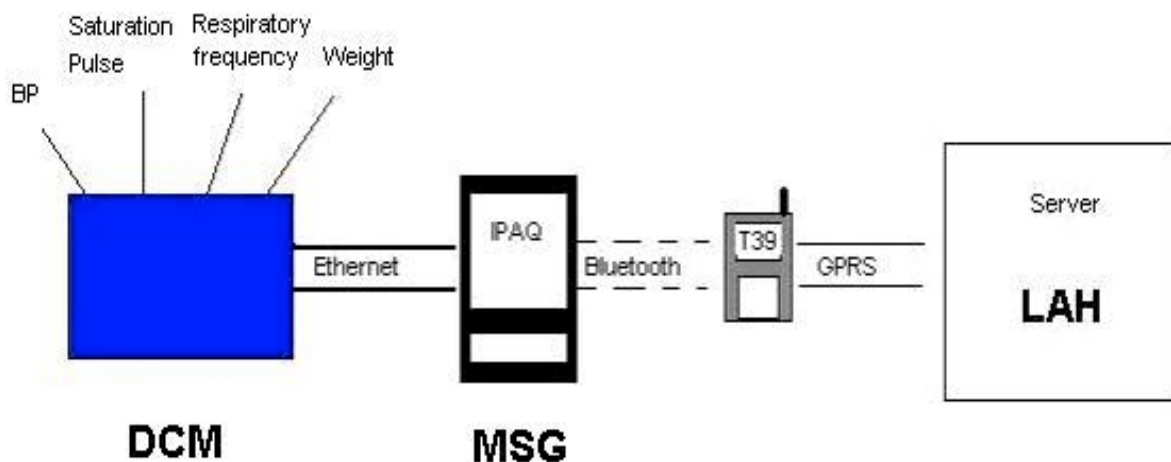

Figure 2. Overview of the status control system.

The system must make sure that the measurements are carried out according to certain rules and regulations. All data collected from the DCM must also be filtered to make sure that only valid data are forwarded to the server. Optionally, the filtering part can be placed upon the server, but that would generate unnecessary traffic from the MSG.

3.2.1. DCM

The DCM consists of a number of measuring devices the patient can use to perform the following measurements:

Saturation: The measurement device for saturation is a small clip that the patient places on his/her middle finger. It uses light to determine the amount of oxygen in the patient's blood. The saturation device is constantly seeking for a signal even if it is not attached to a finger, and will therefore have a small lamp shining all the time. To ensure the patient that he/she has put on the device properly, a small diode on the front of the DCM will be switched on when proper measurement values are received from the saturation device.

Pulse: The device for measuring the patient's pulse is the same as the saturation device. The pulse will be continuously measured once the clip is placed correctly on the patient's finger.

Weight: The device for measuring the patient's weight is a large scale. The scale continuously sends data to the system as soon as it gets a stable reading.

Respiratory frequency: To measure the respiratory frequency the patient uses a nose clip. The nose clip measures the difference between the patient's inhalation and expiration. The nose clip starts to send data as soon as it gets a good reading from the patient. Patients that are being treated with oxygen respirators can have problems attaching the device properly, but the oxygen itself will not cause any incorrect readings.

Blood pressure: A cuff that the patient must strap upon his/her upper arm measures the patient's systolic and diastolic blood pressure. This measuring device is a bit different from the other in the DCM since it requires an action by the patient. The patient must confirm that he/she has put on the cuff by pressing a button located on the front of the DCM. The blood pressure is measured by a pressure sensor located in the cuff that can sense the patient's pulse.

All measurement devices in the DCM send data using RS232 channels. A special circuit board acts as an RS232 hub and gathers all the incoming channels to one. This channel connects to a TINI (Tiny Internet Network Interface) [17] that transforms the RS232 signal to an Ethernet signal, which can communicate with the network device of the MSG. A PIC processor is placed in the DCM as a master controller that regulates the sending and receiving of data. The communication between the PIC and the MSG is regulated by a protocol that is implemented in the PIC, see figure 3.

The notation of the protocol is $\langle Xn \rangle Y$, where X represents the type of the signal, n decides what module the signal refers to, and Y is the argument. The symbol n stands for a digit 0 – 5 according to the following representation:

0	Master controller (PIC)
1	Optovent module (Respiratory frequency)
2	NONIN module (Saturation/Pulse)
3	Suntech BP module (Blood pressure)
4	Scale (weight)
5	Optional modem (not implemented)

The protocol allows you to send control signals $\langle Cn \rangle$, receive measurement data $\langle Dn \rangle$, receive responds to control signals $\langle Rn \rangle$, receive the status of the buttons $\langle Bn \rangle$, and to receive other signals $\langle En \rangle$.

Further information of the protocol is given in [18].

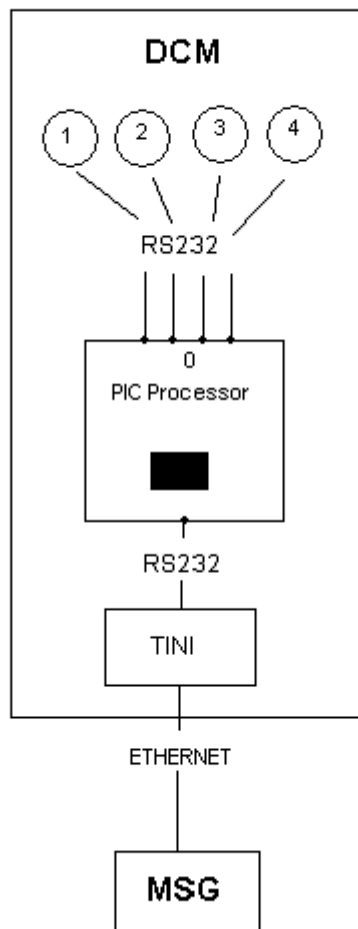

Figure 3. Overview of the DCM system

3.2.2. MSG

The medical service gateway consists of an iPaq PDA with both Ethernet and Bluetooth communication abilities. The MSG is basically a software program, which would perform the following tasks:

- ÷ Monitor the DCM
- ÷ Receive measurement data from the DCM
- ÷ Initiate measurements
- ÷ Perform measurements according to certain rules
- ÷ Filter measurement values to exclude false or misleading data
- ÷ Compare measurement data with limit values and send an alarm if the data is out of range
- ÷ Send approved measurement data to the server
- ÷ Receive instructions from the server

3.2.3. Mobile Phone

The cell phone is a SonyEricsson T39 with Bluetooth connection. The cell phone receives data via Bluetooth and forwards it to the server using GPRS on the public mobile phone system.

3.2.4. Server

The server will receive measurement data from the MSG and store it in a database. It will also provide an interface for caregivers to access data as well as provide profiles for patients using the system.

3.3. Interface program

The interface program will be HTTP-based enabling caregivers to access it from any computer connected to the Internet. Caregivers will log into the system using personalised user names and passwords. Graphically the system reminds of the SÁLAH system, see section 6.3, and the idea is that they will be merged in the future.

The program will list all patients that are, or have been, using the status control system. For each patient, there will be information of how often the patient should perform measurements, as well as information of the limit values for these measurements. Caregivers can adapt the program to each patient, and admit what the limit values will be for each patient. If the patient's measurements exceed, or fall below these values the program will issue a warning to the caregivers.

Using the program, caregivers can change settings for the measurement procedures. For blood pressure the system will be defaulted to separate measurements, which means a single systolic and diastolic blood pressure is measured, but the caregivers can alter this to a continuous measurement. The continuous measurement takes place over a period of time where the patient keeps the blood pressure cuff on, and a new blood pressure is measured in regular intervals. The caregivers can add the period of the continuous measurement as well as the intervals between each measurement in the system. Caregivers can also choose to let measurement values be displayed on the DCM. This can be useful if patients wish to see their measurement values themselves.

3.4. Communications

3.4.1. Signals from the DCM

All signals from the DCM arrive as a stream. For instance, [18]:

<D4>76<D2>97%<D3>S120<D3>D80<D2>97%<D2>97%<D2>97%<D2>97%

This stream of measurement data informs that the patient's weight is 76 kg, systolic blood pressure is 120 mmHg, diastolic blood pressure is 80 mmHg and saturation is 97 percent. As demonstrated, the signals from the DCM contain many different types of information. Therefore, an important part of the system is to filter the information properly so that each type of information is analyzed by the correct part of the system.

As stated, it would be preferable if each type of measurement data from the DCM is analyzed by a specialized corresponding part in the MSG. Hence, one part should analyze BP data another saturation data etc. This will make it easier to implement limit values for approving correct data and to eliminate false ones. It is also important to have a good implementation of vital signs limitations, so that the system can raise the alarm if a patient's values become unhealthy. Since most measuring devices will send data in a constant rate to the system, no matter if a patient performs a measurement or not, it is of high priority that the analysis is performed correct.

The DCM can also send signals that do not include any measurements, but that acknowledge its status. When the DCM is powered up it sends the signal <E0>W, which means *Wake up from power on*. To get a good indication of the DCM's status this signal is important for the system to identify. To make sure that the system has a connection with the DCM some requests must be made on a regular basis. For instance send <C0>C, which represents asking the *Master controller* about the *Baud rate* setting, the reply will be either <D0>9 or <D0>1 [18].

3.4.2. Signals to the DCM

The system shall use the commands defined in the protocol for the *Master Controller* to control the DCM. All measuring devices send data continuously except for the blood pressure module, which demands some feedback from the patient. The patient must confirm that he/she has placed the cuff correctly on his/her upper arm by pressing the button located on the symbol for blood pressure on the front of the DCM.

As soon as valid data has been received from one of the measuring devices, the system shall light the diode for the corresponding device. This is done by sending the signal <Cn>T to the *Master Controller*; where *n* represents which module diode that should be turned on, see section 3.4.1.

3.4.3. Communication to the Server

The data sent to the server at LAH consists of approved measurement data from the patient, and is routed from the MSG to the server at LAH using the cell phone's GPRS connection. One part of the system should be responsible for the communication to LAH, so that other parts do not have to deal with that. For instance a special Java class to which one sends streams of data that one wants to be forwarded to the server.

3.4.4. Communication from the Server

The communication with LAH must be a two-way communication. One part of the system must therefore be able to receive data from LAH.

The information from the server consists, for instance, of changing the blood pressure module from taking one-time-measurements to perform measurements continuously over a period of time. The caregivers can alter this using the web-based interface (see section 3.3) connected to the server. A continuous measurement takes place with decided intervals over a period of time. All this information comes from the caregivers using the interface. The information can also contain information from caregivers to change the vital signs limits for a patient. The vital signs limits are values to which the measured values will be compared. An alarm will be sent to the caregivers if the measured values are outside the limit values.

3.5. Measurements

To get a better understanding of how the system will act and react, this section covers the type of signals that will be sent and received in order to perform measurements. Some modules send special status bits of data that indicates if the module believes the measured value is valid.

3.5.1. Blood Pressure Separate Measurement

The patient puts on the cuff and presses the button to initiate a measurement. The system acknowledges this and starts the measurement process. The measurement is initiated, the diode is turned on, the cuff is pumped up, and the system listens for measurement data from the BP-module. When data has been received and approved, it is forwarded to the server, the diode is switched off, the patient removes the cuff and the measurement is finished.

Event	Receive	Send
Receive BP-button push	<B3>B	
Switch on BP-diode		<C3>T
Initiate measurement		<C3>START_BP
Receive data from measurement	<D3>S120 <D3>D80	
Verify measurement data		
End measurement		<C3>ABORT_BP
Switch off BP-diode	<C3>F	
Send data to server		

Table 1. Blood pressure separate measurement.

For further information regarding the precise commands to send and for the structure of the data packages the reader is referred to [19].

3.5.2. Blood Pressure Continuous Measurement

The system receives information from the server that the patient will perform a continuous blood pressure measurement. A continuous measurement takes place during a longer period of time when a number of separate blood pressure measurements are performed with regular intervals. The system acknowledges the patient pressing the BP-button and initiates the measurement. The cuff is pumped up and the system receives data from the BP-module and switches on the BP-diode. When the data is verified it is sent to the server and the cuff deflates. The patient keeps the cuff on and a new measurement takes place after a while. During this time the diode is always switched on. Data is sent to the server after each measurement. After the measurement is completed the diode is switched off, the patient removes the cuff, and all the remaining data is sent to the server. The measurement is completed.

Event	Receive	Send
A continuous measurement signal is received from the server.		
Receive BP-button push	<B3>B	
Initiate measurement		<C3>START_BP
Switch on BP-diode		<C3>T
Receive data from measurement	<D3>S120 <D3>D80	
Verify measurement data		
Send data to server		
Repeat the measurements on a regular basis	See above	See above
End measurement		<C3>ABORT_BP
Switch off BP-diode	<C3>F	
Send remaining data to server		

Table 2. Blood pressure continuous measurement.

For further information regarding the precise commands to send and for the structure of the data packages the reader is referred to [19].

3.5.3. Respiratory Frequency

The module that measures respiratory frequency, called Optovent R_rR technology, sends data continuously whether the patient performs a measurement or not. The system must therefore receive measurement data all the time and analyse them as they arrive. As soon as verified data has been received the diode representing breathing frequency should be switched on and the system shall send data to the server as it arrives. When data no longer can be verified and approved from the breathing frequency module the patient has finished the measurement. The diode should be switched off and remaining data sent to the server.

Event	Receive	Send
Receive measurement data	<D1>20	
Verify measurement data		
Switch diode on if data is approved		<C1>T
Send data to the server		
Repeat above until incoming data is no longer approved		
Switch off diode	<C1>F	
Send remaining data to the server		

Table 3. Respiratory frequency measurement.

For more information regarding the respiratory Optovent module the reader is referred to [20].

3.5.4. Saturation

The module that measures saturation sends data continuously, whether the patient performs a measurement or not. The system must therefore receive measurement data all the time and analyse these as they arrive. As soon as verified data has been received, the diode representing saturation should be switched on and the system will send data to the server as it arrives from the module. When data no longer can be verified and approved from the saturation module the patient has finished the measurement. The diode should be switched off and remaining data sent to the server. It can be complicated to decide whether the patient has removed the saturation module or is simply moving, therefore a lot of testing must be performed to help decide this.

Event	Receive	Send
Receive measurement data	<D3>97%	
Verify measurement data		
Switch diode on if data is approved		<C3>T
Send data to the server		
Repeat above until incoming data is no longer approved		
Switch off diode	<C3>F	
Send remaining data to the server		

Table 4. Measuring the saturation.

For more information regarding the saturation module the reader is referred to [21].

3.5.5. Pulse

The module that measures pulse sends data continuously whether the patient performs a measurement or not. The system must therefore receive measurement data all the time and

analyse them as they arrive. As soon as verified data has been received the diode representing pulse should be switched on and the system will send data to the server as it arrives from the module. When data no longer can be verified and approved from the pulse module the patient has finished the measurement. The diode should be switched off and remaining data sent to the server.

Event	Receive	Send
Receive measurement data	<D3>65	
Verify measurement data		
Switch diode on if data is approved		<C3>T
Send data to the server		
Repeat above until incoming data is no longer approved		
Switch off diode	<C3>F	
Send remaining data to the server		

Table 5. Measuring the pulse

The module measuring the pulse is the same as measuring the saturation. The reader is therefore referred to [21] for more information.

3.5.6. Weight

The module that measures weight sends data continuously, whether the patient performs a measurement or not. The system must therefore receive measurement data all the time and analyse them as they arrive. When data is received which indicates that at least 20 kg has been put on the scale and remains there for at least two seconds, the patient has initiated a measurement. The system should also be able to compensate if the patient uses some kind of support, for instance a chair, by reducing the chairs weight from the measured weight. This can only be done if the patient places the chair on the scale at least five seconds before initiating the measurement. When the system recognizes that a measurement takes place, the diode representing the weight should be switched on to indicate that the system receives data from the scale. When a stable value has been received the diode should be switched off to indicate for the patient that the measurement is completed. The measurement data is sent to the server.

Event	Receive	Send
Receive measurement data	<D4>65	
Verify measurement data		
Switch diode on if data is approved		<C4>T
Confirm that the weight remains stable on the scale.		
Send data to the server		
Switch off diode	<C4>F	

Table 6. Measuring the weight.

3.6. Error Management

The error management in the system must be able to cope with issues such as measurement devices braking down, no connection with the server is available, or the patient performs measurements incorrectly.

The most important aspect is with a broken measuring device. The caregivers must be alerted by this, preferably by sending messages to the web-based interface, but most important is that the rest of the system continues to function when a single device brakes down. The software of the system must therefore be modulated so that only certain top management routines become aware of the broken device and can take appropriate actions.

If the connection with the server is unavailable, for instance because the cell phone is turned off or the mobile network is down, the system must store the measurement data as well as the time when they took place, and try to send it later with regular intervals.

If the patient performs measurement in an incorrect way and no verifiable data can be discovered, this should be reported to the caregivers. They can then give new instructions to the patient on how to perform measurements correct or they can come home to the patient and test the equipment. It can also be an indication that the measuring device is broken.

To facilitate for the patients and to minimize possible anxiety, there will be no confirmations given to the patients when they have performed a measurement. According to the caregivers a patient's anxiety could increase if a confirmation were to be given. If something should go wrong and the system should indicate this, the patient would not know what to do about it except contacting the caregiver.

4. Using OSGi?

When using a system as complex as OSGi there are many advantages as well as disadvantages. In this section emphasis is put on the key benefits and the largest drawbacks.

4.1. Benefits

4.1.1. Secure Messaging

The data that will be sent between the mobile system and the server consists of sensitive material, such as patient measurement data. In order to keep the system as secure as possible both authentication and encryption must be used. Gatespace has, in their OSGi implementation, specified an API for managing sending and receiving messages in a secure way, called Secure Messaging. The API supports:

- ÷ Asynchronous datagram service
- ÷ Secure platform-to-platform delivery
- ÷ Each message has a built-in digital signature and can be encrypted
- ÷ Delivers messages using any transport bearer available
- ÷ Hides the details of transportation to the clients using it
- ÷ Messages can be given an expiration time

By using Secure Messaging to manage all data sent between the mobile system and the server a lot of technical issues will be solved. All messages will be encrypted and authorized, giving a high security level. Since the means of transportation can basically be any available technology, it will pose no problems to implement the use of a mobile system with GPRS.

4.1.2. Error Management

If a measuring device will be disabled or become broken without prior consent, OSGi has routines that can manage this. For instance, if a bundle managing the Optovent module loses contact with the device, the service of measuring respiratory frequency will be disabled. The system can then easily detect this and inform the administrators of it, without having to rely on the patient perceiving this. The rest of the system will not be affected by this and can continue to function with the remaining measuring devices.

4.1.3. Remote Access and User Management

OSGi provides an API for accessing systems from remote distances. In this system it could be very valuable to be able to monitor the DCM and MSG systems manually when needed.

There may be an obstacle with implementing this though, and that lies in the ability to reach the system since it is using GPRS. If it turns out to be impossible to reach the system from the outside this must be discussed with the involved GPRS provider, Vodafone Sverige.

User Management is a service included in OSGi that allows systems to have authorization and authentication controls for anyone accessing it by remote access.

4.1.4. Support

Gatespace will provide phone and email-based support to help out with any problems that might occur during the implementation of the system. A 1600 pages long documentation over Gatespace implementation of OSGi is also available, [14].

4.1.5. Future Development

OSGi is a good choice for future development since it is a very flexible and dynamic system. If other measuring devices will be introduced, they will be easy to implement into the system. Thanks to the bundle architecture it will not require any major changes of the system design. OSGi is based on the idea of multiple services being run in the same framework, and is therefore designed to be an evolving system.

4.2. Drawbacks

4.2.1. Java compatibility with the iPaq

Some restrictions are set by the iPaq's Java environment. Since the system will be run on the iPaq, it is vital that the Java environment on that machine is compatible with Gatespace's OSGi release.

Gatespace SGADK 3.2 for service gateways is compatible with the following Java versions:

- ÷ Java 2 Standard Edition (J2SE) 1.2.2 and 1.3
- ÷ Java 2 Micro Edition (J2ME) Foundation Profile 1.0
- ÷ Personal Java 1.2a

4.2.2. Understanding OSGi

Developing in OSGi is a bit different from developing without a framework. The developer must have a large understanding of how OSGi works to be able to take full advantage of it. OSGi is based upon numerous APIs of all the features. The code must be strict with interfaces, listeners and handlers for most bundles that will be implemented. It takes time for an inexperienced programmer to come to the knowledge required to be able to develop in

OSGi. How long that takes to reach is not known, however, in my opinion it could take several days.

The developing process will therefore take extra time compared to developing a system without the use of OSGi. Of course such a system may have several complicated issues that also need to be solved before the system can become usable.

4.2.3. OSGi on the Server

It must be understood that most of the features of using OSGi, which are listed above, will not become real unless the server is also running OSGi. Secure messages as well as other features depend upon OSGi to OSGi communication. Therefore, if it is decided not to run OSGi on the server, I see no real point in using it on the client side.

4.2.4. Support

As mentioned in the advantages of OSGi, Gamespace will provide mail and phone-based support for the developers. However, no one involved in the project has used this support so far, and therefore we have no knowledge about the quality of the support.

4.3. Other Options

The option of developing a system without OSGi must also be considered. At the first glance on the requirements specification, one can easily come to the conclusion that such a system will be fairly easy to develop. However a few key issues must be resolved.

- ÷ Error management.
If a measuring device will brake, or lose functionality it must be reported to the administrators. The system must have routines that can manage such an event and must also be able to let the rest of the system run as smooth as possible, even with one device broken.
- ÷ Sending and receiving data.
A lot of data needs to be sent back and forth to the server. All data must be encrypted and authenticated due to the sensitive information it holds. Routines for this must be developed and thoroughly tested.
- ÷ Security.
Except for the data communications mentioned above, the system itself must be secure. It cannot be allowed to crash because one or more routines stop functioning.
- ÷ Remote access.
Building a system that can manage remote access with high security is a complex project that can take a long time before it is stable and thoroughly tested.

- ÷ Ability to manage a large number of MSGs.
Future enhancements will most likely include several patients performing measurements with different MSGs. Hence, it is important that the system can manage more than one MSG at the same time.

4.4. Conclusion

Considering all the advantages and disadvantages of using OSGi, the conclusion is that OSGi should be used in the project. The benefits from using a service gateway are very large, especially when considering future development of the system. The cost of extra time to learn OSGi will, with high probability, be returned when development proceeds into later stages.

The ability to make secure systems must be of very high priority when developing systems for healthcare. OSGi provides excellent services and routines for this, which makes it a very good base upon which to build the system.

5. Anoto Technology

This section covers Anoto Functionality and technology. The information in this chapter is taken from Anoto™ AB's website [22], [23], and from the Anoto ADK documentation, [24].

Anoto AB was founded in Lund 1999 as a subsidiary of C Technologies. Anoto has developed a unique technology called “The Anoto Functionality” and it consists of three different parts.

- ÷ Digital paper with Anoto pattern
- ÷ Digital Pen
- ÷ Service Infrastructure

A tiny camera in the digital pen registers the pen's movements across the digital paper. The paper is covered with a small grid surface that the pen can read, so it knows exactly where on the paper it is, and can therefore store the pen strokes as a series of map coordinates. By marking with the pen in the special SEND box on the paper the digital pen sends the stored sequence of coordinates to the service infrastructure. The owner of the digital paper is stored in the infrastructure and the coordinates are forwarded to that address. The recipient can then translate the coordinates to an exact image of the handwriting, an image that can be displayed on any computer, mobile phone or be received as a fax [23].

5.1. Anoto Pattern and the Digital Paper

The digital paper is basically a normal paper, but with the distinction that it is covered with a proprietary dot pattern. The pattern, which is irregular, consists of small dots with an average spacing of 0.3 mm. To the human eye the pattern makes the paper perceived as grey-shaded. The digital pen needs to “see” 6 x 6 dots to determine its exact location in the full pattern that is approximately 60 000 000 square kilometres large, which is equivalent to the area of Europe and Asia combined.

The irregularity of the pattern enables the creation of different functionality on different parts of the paper. Hence one part can be equivalent to “send an email”, others as “send a graphical SMS”.

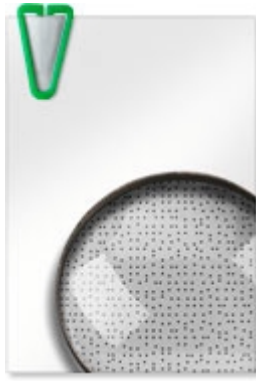

Figure 4. The Anoto pattern on a regular paper [23]

5.2. Digital Pen

The digital pen reminds a lot of an ordinary ballpoint pen with the only distinction that it is somewhat oversized. The pen is activated by removing the cap, and deactivated by simply replacing the cap. Except for an ink cartridge the digital pen consists of a processing unit, a camera, optics, memory, battery, an image processing unit, and a communication unit. While writing the camera continuously takes pictures of the paper and uses this information to derive coordinates of the pen strokes, which afterwards can be sent by using the communication unit.

The pen registers the following information

- ÷ Position
- ÷ Date and time
- ÷ Rotation
- ÷ Inclination
- ÷ Pressure

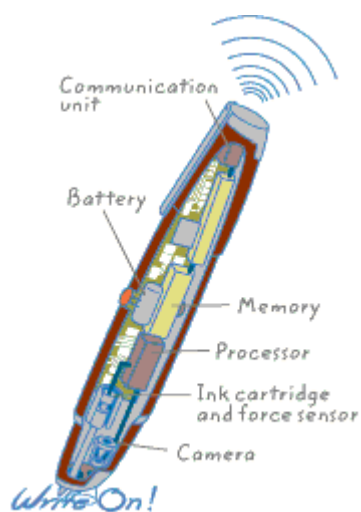

Figure 5. The digital pen [23]

Today there are two (soon three, according to Nokia) brands of digital pens available on the market, SonyEricsson's Chatpen and Logitech's io pen. The difference between the two is their communication units. The Chatpen uses Bluetooth and is designed for network based services using a mobile phone, but can also be connected via a PC. The Logitech pen on the other hand is designed to be used directly to a PC, and for applications used on that particular PC. It uses a docking device to communicate with the PC through the PC's USB port.

In the project described in this thesis a SonyEricsson Chatpen is used together with a mobile phone with GPRS connection to the Internet. The Chatpen communicates with the mobile phone using Bluetooth.

5.3. Service Infrastructure

The service infrastructure consists of two parts, a Paper Lookup Service (PLS) and an Application Service Handler (ASH). The PLS resides at Anoto and contains information of all owners of different parts of the full pattern. The ASH is a service provider that provides either an open service, developed by anyone who has licensed a piece of the pattern, or a standardised service, an Anoto standardization of the functionality, i.e., e-mail, fax or SMS. The ASH is responsible for interpretations and processes of the pen data it receives, the pen itself is application independent.

A pen transaction takes approximately 20 seconds to perform and is divided into four steps, see figure 6.

1. The pen sends a request to the PLS when the user ticks in the "Magic Box" on the digital paper.
2. The PLS replies with the address of the ASH
3. The pen sends data to the ASH over HTTP.
4. The ASH receives the information and can decide if it wants to accept or reject it. Depending on the application it may or may not send a message back to the pen, or send a message to a third party person.

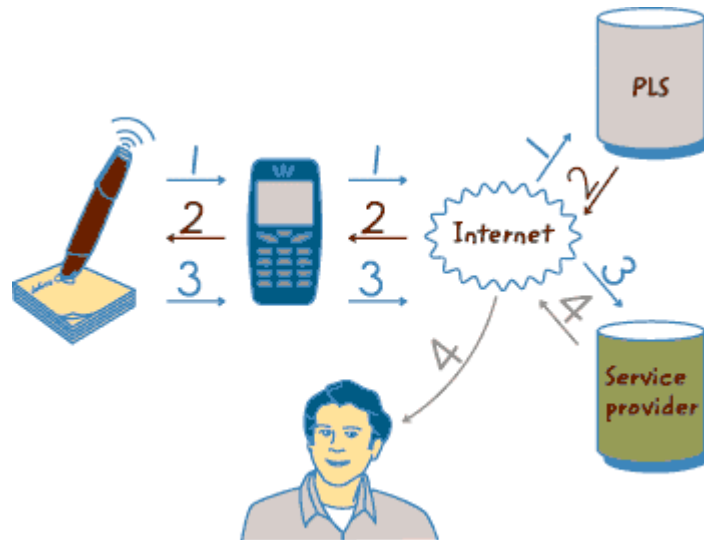

Figure 6. A pen transaction [23].

5.4. Security

Anoto functionality can have three different levels of security.

- ÷ Default
- ÷ Encryption
- ÷ Encryption and authentication

The communication between the pen and the PLS is always encrypted and authenticated, but encryption and authentication of the communication between the pen and the ASH is optional. The system described in this thesis uses the highest level of security available, encryption and authentication. The communication between the pen and the ASH is encrypted using a 1024-bit RSA algorithm and the PLS also provides the pen with a special ticket authenticating it as a valid pen. The ASH receives the ticket and knows that the pen is validated.

There is also the possibility to authenticate the user of the pen, but that has to be managed by the ASH. For instance, the user must provide a PIN-code that the ASH authenticates.

6. The SÅLAH system

This chapter describes the SÅLAH system that was developed during the course of this project. The reader is also referred to the requirement specification, [25].

6.1. Overview

SÅLAH is a Swedish abbreviation and stands for "Pain-Action at the hospital based home care clinic" The main objective of SÅLAH is to enable more frequent pain assessments for patients subject to advanced home healthcare. The idea is that patients use a digital pen to send in pain assessments two or three times a day, and that the caregivers can take part of these assessments and use this data in their medical decisions. The previous work on the system included a base for the requirement specification and a low-fi prototype.

There is an ongoing quality assurance work at LAH, which aims to develop and maintain certain guidelines for actions when a patient reports severe or moderate pain. The pain assessments are performed using a visual analogue scale (VAS scale) that is a 100 mm wide line on which the patients mark their current pain. A mark at the left side of the line (VAS 0 mm) means no pain at all and a mark at the right side of the line (VAS 100 mm) means severe pain.

A special assessment form was developed, see Appendix A, which is called the pain diary, and the patient is instructed to make the assessment on this form. The pain diary has room for three assessments to simplify making three assessments per day. There are also special areas of the pain diary where caregivers enter patient data such as patient identification and prescribed analgesics. The assessment the patient makes consists of the following data:

- ÷ Date
- ÷ Time
- ÷ The number of extra doses of analgesics since the last assessment
- ÷ The VAS value
- ÷ The author of the assessment
- ÷ An identification signature

As mention in chapter 5.2 the pen registers the time of all pen strokes. Therefore, it can be considered unnecessary to have a date and time section of the assessment form. However, the form itself is considered a medical paper and caregivers must be able to confirm that the forms were filled out the same time as the pen strokes were made. The pen's timestamps also enables the caregivers to view the exact time a patient took his/her medication, if the patient put a mark in the box for extra doses every time he/she took the medication.

"The author of the assessment" refers to information about who made the markings on the assessment form. The patient always makes the pain assessment, but in some cases the

patient's medical condition makes it necessary for another person, for instance a relative or medical staff, to fill out the form.

The identification signature was implemented to ensure that the assessments were not filled out under a false name. The signature is a digit combination depending on which pen is used. Of course, if the other person knows the signature and where to put it, there is no way to determine if the assessment is valid, but it helps exclude younger relatives that see the pen as a new toy.

The main SÅLAH system is a Java web application running on a Tomcat web server. It consists of two parts:

- ÷ Receiver application
- ÷ Clinical application

The receiver application is an ASH for an open service, as described in section 5.3, which receives assessment data from a digital pen and stores it in a database. The database is a Microsoft SQL Server 2000 DBMS. For more information regarding the receiver application as well as the database entity, the reader is referred to the master thesis "Application Development for Advanced Home Healthcare", January 2003, [3]. My involvement in the development of the receiver application was fairly small, since focus for me was the clinical application as well as the status control system.

The clinical application is a three-tier web application that consists of Java Server Pages, Java classes and a DBMS, as mentioned above. The Java classes represent different entities in the database and JSPs provide dynamic HTML for the user interface. A special class, a JavaBean, manages all communications between the user interface and the database system. Information regarding the JavaBean can be found in the thesis mentioned above.

6.2. Method

The task for me, and my collaborate involved in this project, was to realize and implement this system so that it fulfilled the requirement specification, [25]. We began by developing a high-fi prototype, based on the previous low-fi prototype. The prototype was thoroughly tested and evaluated by the research group and the caregivers at LAH. Step by step functionality was introduced in the prototype until we had a complete system.

The system underwent most of the testing procedures during the implementation stage. One major system test was performed to exclude any defectiveness we could find. Most of the testing performed was aimed at the digital pen, the receiver application, and the database queries.

6.3. The Clinical Application

The clinical application is used by caregivers to monitor assessments and to administer users and digital pens. It consists of three tiers:

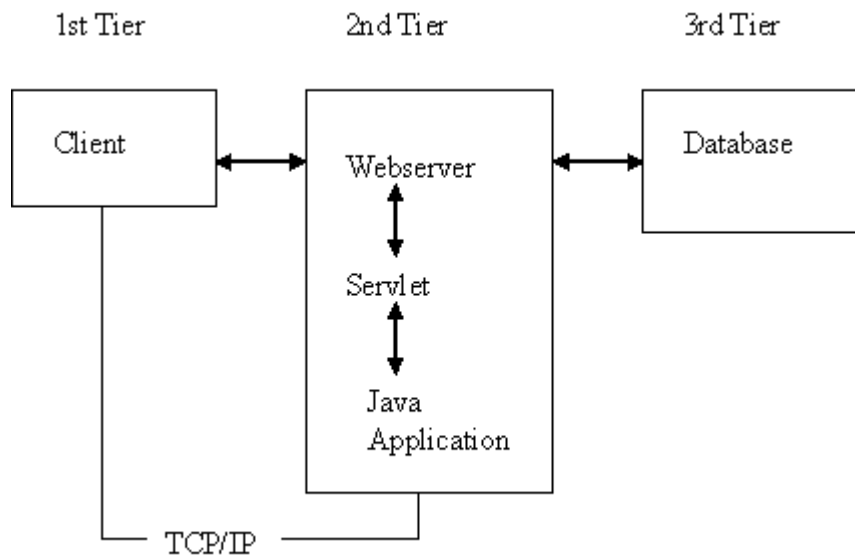

Figure 7. Structure of the clinical application

The user interface is based on a low-fi prototype created by the project during the spring and the summer of 2002. The development started by creating a high-fi prototype, which was thoroughly tested and discussed with caregivers at the clinic.

In general, the user interface consists of two sections, the menu and the main content. In the menu there are navigation facilities and the main content area shows information and collects inputs from the user. The user interface can be reached from the Internet over HTTPS, an SSL encrypted HTTP connection. The following sections describe the various pages in detail.

6.3.1. Logging into SÁLAH

The login page is the first page the user encounters. The user must provide a user name and a password to enter the system. If a valid user name and password is entered the user is directed to the active patients content, section 6.3.2, otherwise an error message is displayed. To authenticate users the system uses Tomcat built-in authentication mechanism [23]. There are two different kinds of user roles, administrators and regular users. The difference is that administrators may add new users and change password of existing ones as well as changing the administrator status of all users, se figure 8.

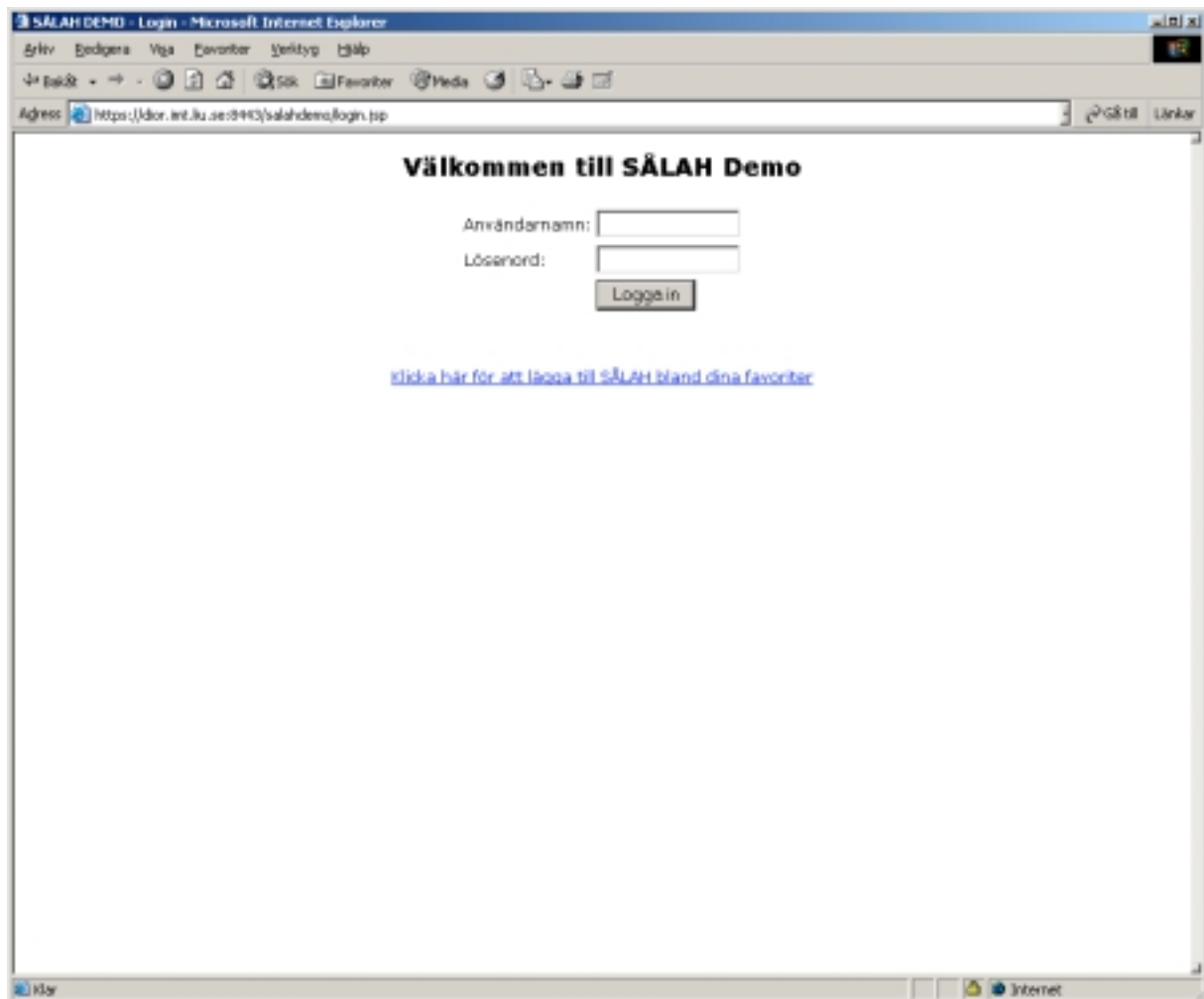

Figure 8. The login page

6.3.2. Active Patients

The active patients page is shown when users log into the system. All patients who are using a digital pen and perform pain assessments for the moment are listed here. The list contains name and social security number for each patient as well as the date and time for their latest assessment. Warnings to the caregivers are issued here. For instance, if a patient reports a VAS pain value, which is at least 20 mm higher than the latest value, a warning symbol is displayed next to the patient's name.

6.3.3. Inactive Patients

The inactive patients page is very similar to the active patients page with the distinction that it only lists patients that are currently not using a digital pen to assess pain, but may have done so in the past or are about to start. From here, caregivers can activate patients by pressing a button next to the patient's name and social security number.

6.3.4. Patient Information

This page is shown when the user clicks on a patient's name in the active patients page. The page shows a lot of information regarding the patient and his/her assessments.

Patient data includes name, social security number, current assessment frequency, current equipment used, authentication signature (see section 6.1), and start date of the period. A period is the time when the patient actively uses a digital pen to perform assessments. The user can alter both the patient's activity level as well as the assessment frequency. This is done by clicking the buttons next to each value in the top right corner of the page.

Assessment data includes graphical images of the two latest assessments the patient has performed, as well as a small diagram over the last three days reported pain. The assessments shown are both images of exactly what the patient drew with the pen, as well as the systems interpretations of values from that assessment. The system interprets the VAS value, the number of extradoses, and the author. In association with the images of the patient's assessment the system's interpretations are shown. If a user believes the system has interpreted something incorrectly, he/she can change this by pressing a button next to the assessment.

If a patient has more than two unseen assessments a button is shown that allows the user to see all the unseen assessments. An unseen assessment means that no user has yet viewed it. This also implicates that if a user has, for instance, five unseen assessments, the ones shown on the patient information page are the latest performed assessments.

On the page there are also buttons to print the patient information, proceed to view a diagram over the entire period, or view all the assessments in the current period, se figure 9.

6.3.5. Correct an Erroneous Assessment

If the system failed to interpret the patient's pen strokes or if the assessment is erroneous in some other way, the user can use this page for correcting the error. In this page each data of the assessment is shown in a separate section where the user can alter the system's interpretation. The user can also add a comment regarding why he/she changed the information. All changes of the assessment are time stamped and also registered with the name of the user that performed the change. This is necessary since all the values are part of the patient's medical record. It is also possible to classify the assessment as invalid, and if this is done the assessment will not show up in the application anymore. It will, however, still be stored in the database.

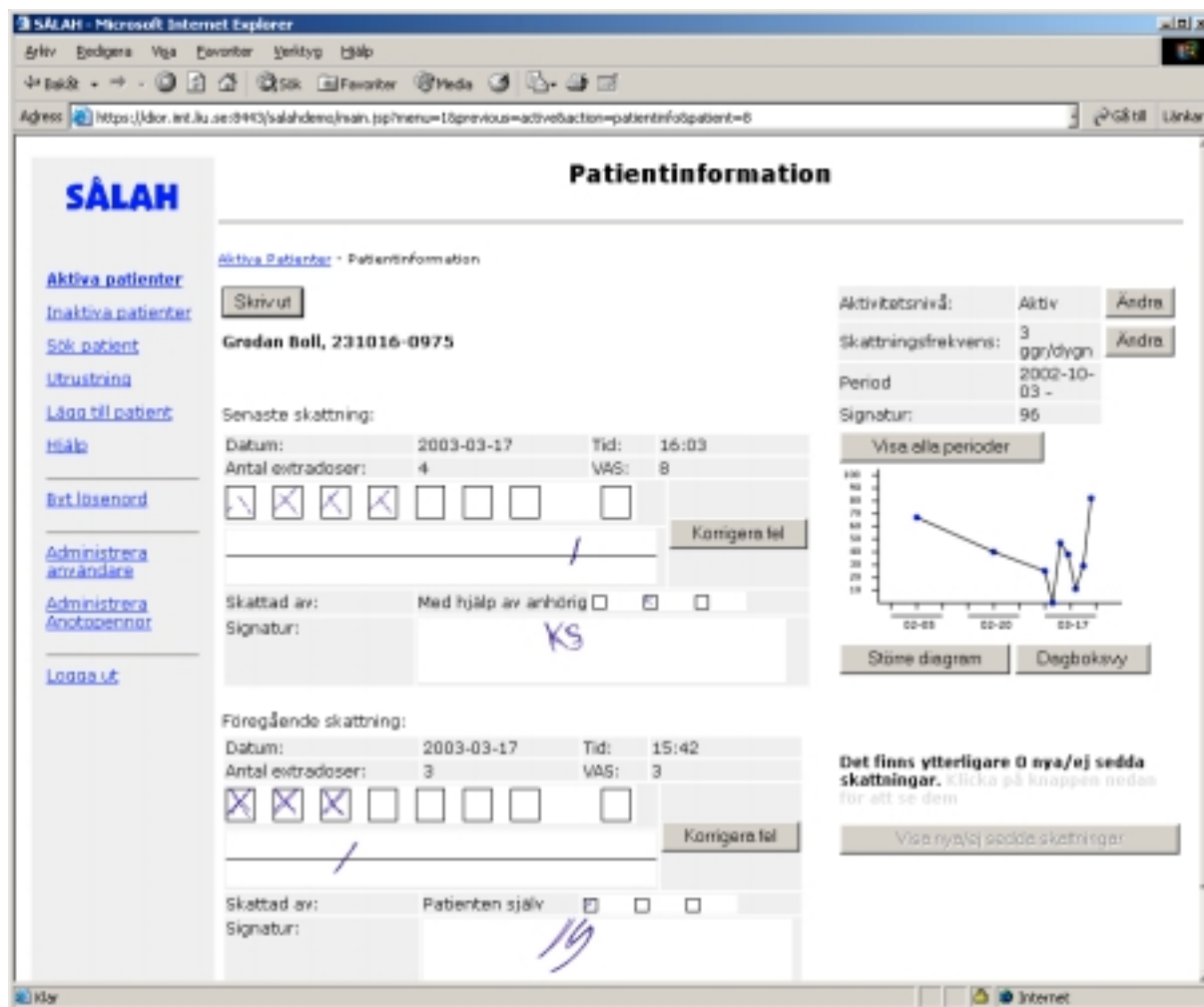

Figure 9. The patient information page

6.3.6. The Diagram Page

The diagram page shows VAS values and extra doses plotted over time. The time span is one active period, but if the period exceeds 10 days, the diagram will be divided for viewing reasons. The diagram also warns the caregivers if the patient has not made the correct number of assessments each day according to the patient's assessment frequency. The diagram can be printed by using the print button on the page. The printed version contains 10 days per page.

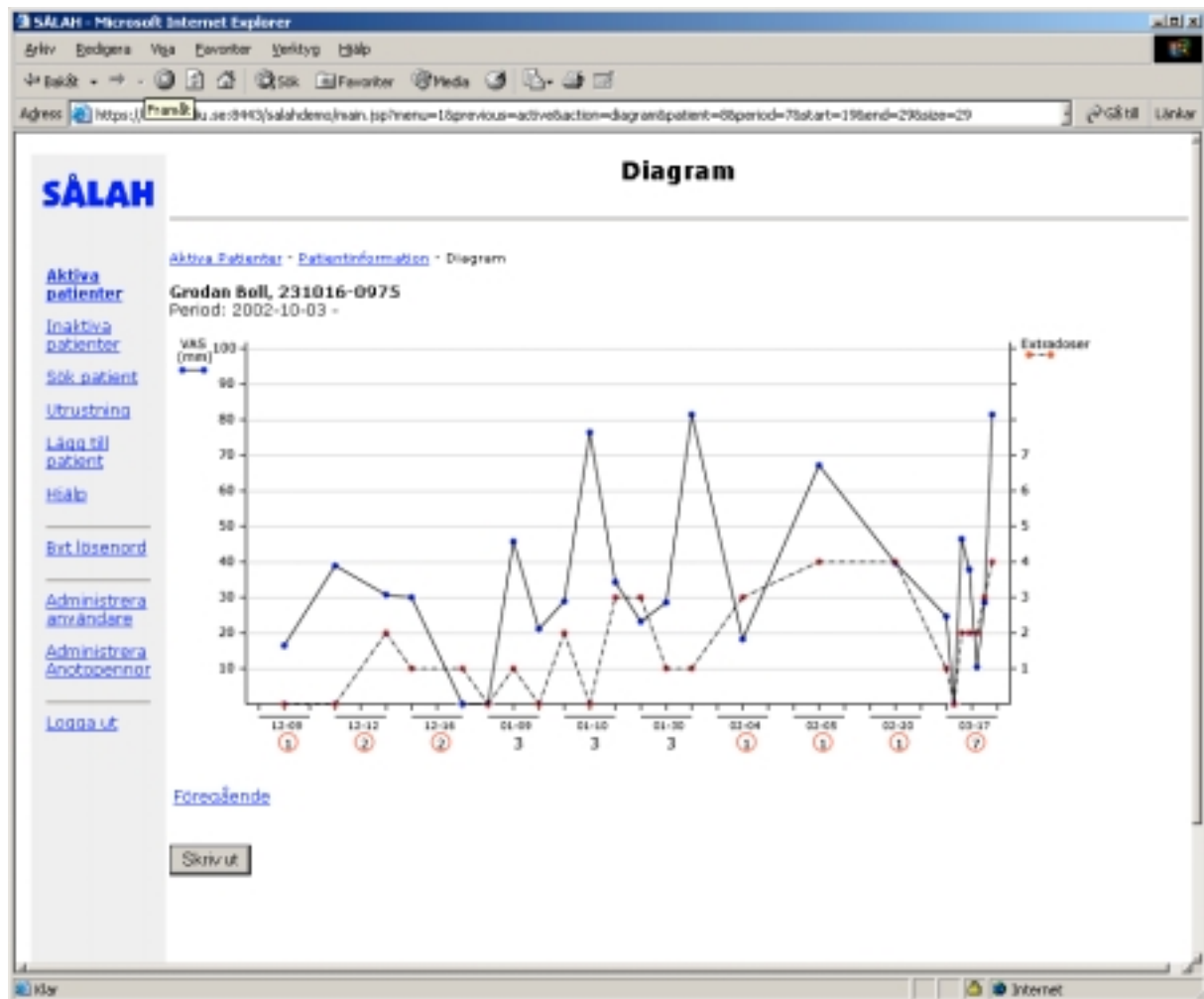

Figure 10. The diagram page

6.3.7. Search Patient

The search page allows user to search for patients in the database. There are three different search criterions:

- ÷ Social security number (SSN)
- ÷ First name
- ÷ Last name

The SSN needs to be equal to the patient's SSN to get a match, but the names can be substrings of the patient's names. For instance, the string "an" matches both "Anders" and "Anna". If the search is made on more than one criterion, all individual criteria searches are combined. The result of the search is presented in a list. If the user clicks on the name of any of the patients presented in the result list, the system redirects the user to information regarding that patient, which is the same as if the user would click on a patient in the active or inactive lists.

6.3.8. Equipment Status

This page shows all equipment in the system and their status. Each equipment set consists of a digital pen, a mobile phone and chargers for both of them, one branching-off box and a bag. If an equipment set is being used the name of the patient using it is stated next to the equipment's identification number. If an equipment set fails or is broken the user can alter the status to "out of order" by selecting the equipment entry in the list. The user can also enter a comment about the status of the equipment, what error symptoms have occurred or which actions have been taken.

6.3.9. Add Patient

To add a new patient to the system the user must provide a valid SSN along with the patient's full name. The SSN is checked for validity by the system before approving the patient. The user can then change the patient's status to active. The default status is inactive. After the patient has been added, the patient is listed under either the active or inactive patient lists.

6.3.10. Help

The help page in the system provides the user with explanations to the menu and the functions the user can perform in the system. The help is structured with hyperlinks to enable the user to find the correct help as fast as possible. There is also an FAQ with common questions and answers about the SÁLAH system, see figure 11.

6.3.11. Administration

For normal users the only system administration they are able to perform is to change their own passwords. Administrators on the other hand, have other menu options that allow them to add or remove other users, and to add or remove equipment sets. In the current implementation it is not possible to change user names, but the administrator must delete the user and then add a new user with the correct user name.

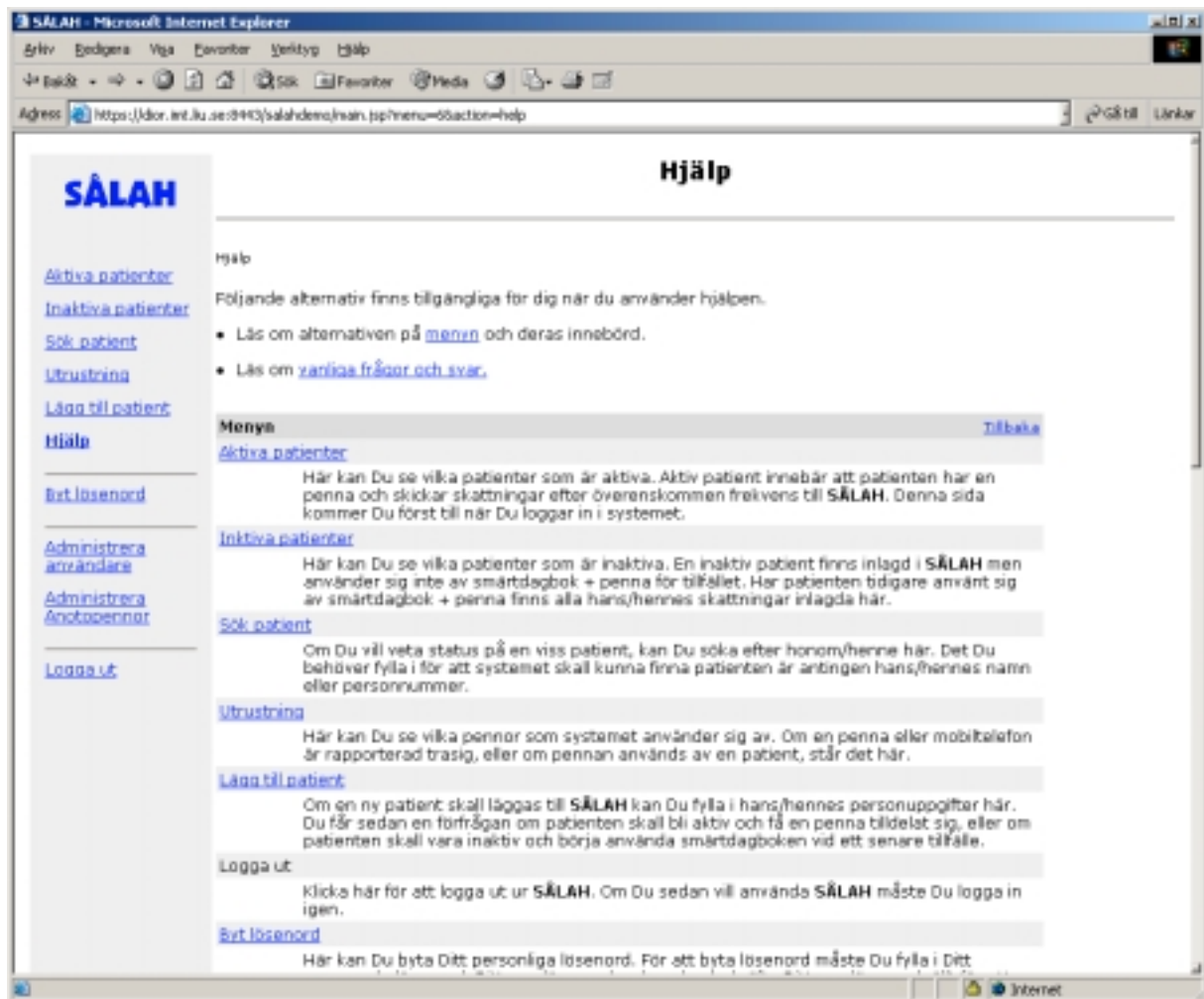

Figure 11. The help page

7. Discussion

This chapter discusses the future work of both the SÅLAH system and the status control system. It also includes reflections of what has been achieved so far and discusses the future for information technology within home healthcare.

The SÅLAH system was taken into service in mid December 2002, when the first patient started to assess pain with a digital pen. The system will continue to run during the first half year of 2003, after that it will be evaluated by the research group at IMT.

The status control system is not yet implemented, but will hopefully become so within the following year.

7.1. IT in Home Healthcare

Home healthcare is one of the most important applications for information technology in the future. A lot of articles have been written and researchers are convinced that IT will revolutionize healthcare, and especially home healthcare. In the author's opinion home healthcare is in desperate need of new relatively inexpensive ways of keeping the normal standard of healthcare. The enormous cutbacks of funding and shortage of educated medical staff in the last years have imposed serious problems for healthcare. This, in combination with the increasing elderly part of the population, make the need for new medical systems urgent, and IT is one of the areas where the medical community needs to adopt itself. There are of course several problems with this. First of all the lack of IT education among the medical employees. Secondly, economy is an important issue. Leaders of the health community are probably not eager to spend a lot of money to develop new systems, when they are having severe problems making the current ones work financially.

Another problem is that the older population are generally more hesitant towards new solutions and technologies. Therefore, a lot of effort must be put into information and reliability. If neither caregivers nor their patients are confident with new equipment and new technologies they will not take advantage of it, and it will be a waste of money and resources. This can be solved by developing new systems in cooperation with caregivers and, to some extent, patients. According to the author's own experiences during the course of this project, caregivers have very important information and aspects that non-caregivers are unable to think of. Involving medical staff in the development also improves their faith in the systems and their educational level.

When developing healthcare systems it is important to also consider the user friendliness of the system. A lot of new systems involve a higher degree of action from the patients and more responsibility is put on them. Therefore, developers must have in mind that patients suffering from illness may not be able to use the same system as healthy ones.

7.2. Future Work and Enhancements

The goal of the research group is to unite the status control system and the SÅLAH system. Both systems address the same medical staff and patient groups. The systems will hopefully be enhanced, so that more parameters can be measured and patients can assess other symptoms than pain.

7.2.1. Status Control System

Since the status control system is not implemented yet a lot of work remains. The most important issue is to get the hardware ready, so software testing towards it can begin. It is important to know how the different measure devices send and receive data. The core of the MSG system can of course be designed and implemented anyhow. The reader is referred to chapter 3.2.2 for more information regarding this.

7.2.2. SÅLAH

SÅLAH's user interface started out as a low-fi prototype in collaboration with the medical staff at LAH. This work was a continuation of Li Hallgren's thesis work, [2]. Afterwards the prototype was enhanced and resulted in a high-fi prototype that was the base for developing the real application. The research group had a lot of meetings with the medical staff during the course of implementing the system and the user interface was constantly improved. The goal was to make the user interface as simple and intuitive as possible due to limited computer experience among the medical staff. The study mentioned in chapter 1 will determine if this was successful or not.

There is an ongoing work in the County Council of Östergötland with the aim to integrate all IT systems within healthcare to a common platform. The platform will have a service called Single Sign-on (SSO) that will allow users to log on via a central authentication server that allows them to access all systems within the platform. SÅLAH and the status control system could be integrated into this and the SSO could be used for authenticating users.

Another addition to the SÅLAH system would be to take advantage of patient signatures more. As of now, the signature that is drawn on the assessment form is only a number, but it would be preferable if the patients could draw their own personal identification signatures that could be matched in the system. This would, however, require a lot of work since the system needs both the patients' signatures and the signatures of the people that assist the patients in filling out the form, for instance relatives or medical staff. This would require a large signature database, but the overall security of the system would improve.

7.3. Summary

The need for IT solutions within home healthcare has increased significantly the last years. The home healthcare organisations need to grow and raise the quality of care since more

patients are submitted to home healthcare. By introducing IT-systems caregivers can achieve a better control over their patients. Researchers point out that IT can revolutionize home healthcare, and the highest benefits come from passive monitoring and active measurements.

The status control system is designed to allow patients to perform non-invasive measurements in their home. The system has not yet been implemented but I have in this thesis tried to describe it in detail. The core of the system is the Medical Service Gateway that will monitor, control and gather data from a Data Collection Module that the patients use to perform measurements. The base of the software system in the MSG should be GATESPACE's OSGi. The benefits from using a third-party system as a framework are numerous. The alternative is to design a complete system yourself, but that would probably require more time, and more technical issues would have to be solved.

The SÅLAH system is designed to allow patients to perform pain assessments from their home using Anoto technology. Caregivers can monitor the assessments and use them in their quality assurance work to maintain certain guidelines when patients report moderate or severe pain. The SÅLAH system was taken into service in a pilot study in December 2002, and will continue to run through the summer of 2003. The system is being used by patients given treatment at home by the healthcare clinic at the Linköping University hospital. After the pilot study, the system will be evaluated by the research group at IMT, to help decide the impact this new technology has within home healthcare.

Except for implementing the status control system, both of the systems mentioned in this report can be improved in the future. For instance, a larger number of parameters could be assessed or measured, and the user interface for both systems can be enhanced. Hopefully the systems can some day be merged to a single system caregivers can take advantage of.

Bibliography

- [1] Leili Lind and Dr Daniel Karlsson. [IT support for advanced home healthcare – improved symptom and status control in the home.] (in Swedish), <http://www.imt.liu.se/mi/Research/HBHC/>, October 2002.
- [2] Li Hallgren. Use of digital pen technologies in home healthcare. Master's thesis, Linköping University, 2002.
- [3] Thobias Ålund. Application Development for Advance Home Healthcare. Master's thesis, Linköping University, 2003.
- [4] Almut Herzog and Leili Lind. Network solutions for home healthcare applications. *Submitted to Technology and Healthcare*, July 2002.
- [5] The Swedish Federation of County Councils. Home healthcare – another dimension within healthcare (in Swedish), 1998.
- [6] Lind L, Sundvall E, Karlsson D, Shasavar N, Åhlfeldt H. Requirements and prototyping of a home healthcare application based on emerging java technology. *International Journal of Medical Informatics 2002, vol 68/1-3 pp 129 – 139.*
- [7] Ruggiero C, Sacile R, Giacomini M., Home Telecare, Department of Informatics Systems and Telematics, University of Genova, Italy, *Journal of Telemedicine and Telecare 1999; 5: 11-17.*
- [8] Rodriguez MJ, Arredondo MT, del Pozo F, Gomez EJ, Martinez A, Dopico A, A home telecare management system, Grupo de Bioingenieria y Telemedicina-GBT, ETSI Telecomunicacion, UPM, Spain, *Journal of Telemedicine and Telecare 1995; 1: 86-94.*
- [9] Paul A. Heidenreich, Christine M. Ruggiero, and Barry M. Massie, Effect of a home monitoring system on hospitalisation and resource use for patients with heart failure. *American Heart Journal, 138(4): 633-640, October 1999.*
- [10] N. Maglaveras, V. Koutkias, S. Meletiadis, I. Chouvarda, E.A. Balas, The Role of Wireless Technology in Home Care Delivery, Aristotelian University, The Medical School, Lab of Medical Informatics, GREECE, and Centre for Healthcare Quality, University of Missouri, Columbia, Missouri, USA, *MEDINFO 2001.*
- [11] http://www.osgi.org/resources/spec_overview.asp, February 22nd, 2003.
- [12] Open Services Gateway Initiative (OSGi), Specification Overview, Version 1.0, January 2000.
- [13] A. Herzog, N. Shahmehri, A. Bednarski, I. Chisalita, U. Nordqvist, L. Saldami, D. Szentivanyi, M. Östring, Security Issues in E-Home Network and Software Infrastructures. Proceedings of the 3rd Conference on Computer Science and Systems Engineering in Linköping, pp 155-161, Norrköping, Sweden, 2001.
- [14] Open Services Gateway Initiative (OSGi), SGADK Documentation, 2001.
- [15] Tortora Gerard J., Principles of anatomy and physiology, 9th edition, John Wiley & Sons, Inc, 2000.

- [16] Kristoffer Berggren, Leili Lind, Daniel Karlsson. [Requirement specification for the Status Control System] (in Swedish), technical report, Department of Biomedical Engineering, Linköping University, 2003.
- [17] <http://www.ibutton.com/TINI>, March 25th, 2003.
- [18] Milton et al., Control commands from TINI to Converter. Internal technical report, 2002.
- [19] SunTech Medical Instruments Inc, Advantage OEM BP Module, Operations Manual, Rev C, 1999.
- [20] OEM Specification, The Optovent RtR Technology, MP 2000-10-09.
- [21] Specifications Nonin OEM II Module, R225-16 utg.1.
- [22] <http://www.anoto.com>, 22nd march 2003.
- [23] <http://www.anotofunctionality.com/navigate.asp?PageID=24>, 25th march 2003.
- [24] Anoto Technical Publications, Development guide for services enabled by Anoto Functionality, 2002.
- [25] Leili Lind, Daniel Karlsson, Li Hallgren, Thobias Ålund, Kristoffer Berggren, Waldemar Bau, Sofie Spångberg, and Christina Hvittfeldt, [Requirement and design specification for the SÅLAH system] (in Swedish), technical report, Department of Biomedical Engineering, Linköping University, 2002.
- [26] The Apache Software Foundation, <http://jakarta.apache.org/tomcat>, December 9th 2002.
- [27] The Swedish Federation of County Councils, SITHS; [Information security in the healthcare process], (in Swedish), 2000, <http://www.carelink.se>.

Appendix A The Assessment form

The assessment form diary is shown in figure 12.

Klinik Patientinformation

Smärtdagbok

Stående ordination, smärtläkemedel:

Extrados, smärtläkemedel:

Datum: Klockslag: Ingen extrados

Extrados sedan förra smärtskattningen:

(sätt ett kryss för varje extrados)

Ingen smärta _____ Värsta tänkbara smärta

Skattad av: Patient Med hjälp av anhörig Med hjälp av personal Skicka till LAH 

Signatur:

Datum: Klockslag: Ingen extrados

Extrados sedan förra smärtskattningen:

(sätt ett kryss för varje extrados)

Ingen smärta _____ Värsta tänkbara smärta

Skattad av: Patient Med hjälp av anhörig Med hjälp av personal Skicka till LAH 

Signatur:

Datum: Klockslag: Ingen extrados

Extrados sedan förra smärtskattningen:

(sätt ett kryss för varje extrados)

Ingen smärta _____ Värsta tänkbara smärta

Skattad av: Patient Med hjälp av anhörig Med hjälp av personal Skicka till LAH 

Signatur:

DIGITAL PAIN EVALUATION  FUNCTIONALITY

Figure 12. The assessment form- the pain diary